

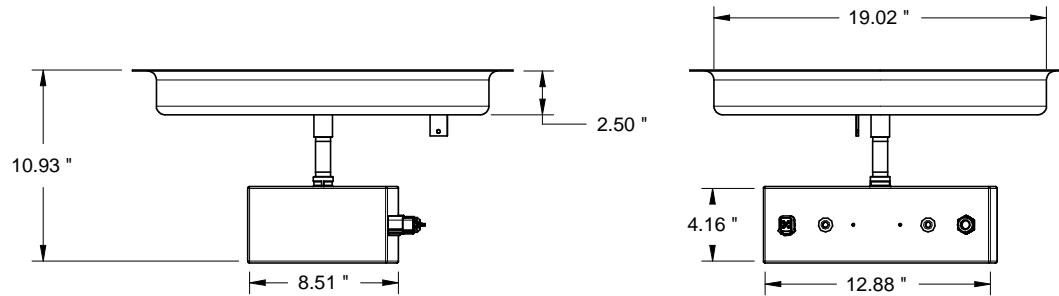

REVISIONS				
ZONE	REV	DESCRIPTION	DATE	APPROVED

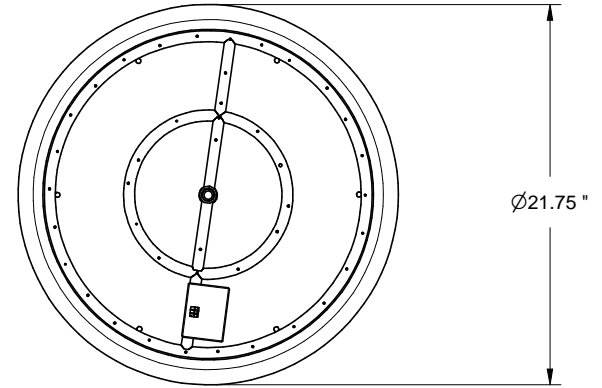

<p>All dimensions are for reference only please allow 2 inches of space on all sides of valve box for clearance. Pan, pipe and valve box are 16 ga 304 stainless steel. Burner ring is 216 stainless steel.</p>	DRAWN	DATE	 <b>Hearth Products Controls Co</b>		
	Tom Hapner	11/05/08			
	CHECKED		<b>19SS150HSI</b>		
	QA				
	MFG		SIZE	FSCM NO.	DWG NO.
APPROVED		A		ref 1000	
SCALE			SHEET		

